

MODEL DVP15-526

15 HP P.D. INDUSTRIAL VACUUM

LARGE, EASY ACCESS
FILTER SERVICE DOOR

HIGH EFFICIENCY
FILTRATION

INLINE FILTER WITH
CONDITION INDICATOR

VACUUM RELIEF
VALVES

INTERNAL MANUAL
FILTER BAG SHAKER

FOURTEEN 5"X41"L
FILTER BAGS WITH
61.6 SQ FT FILTER AREA

HEAVY DUTY
MECHANICAL LIFTER

4" NPT INLET WITH
INTERNAL WEAR STRIP

27.0 US GAL
STORAGE DRUM

8" BALL BEARING
WHEELS

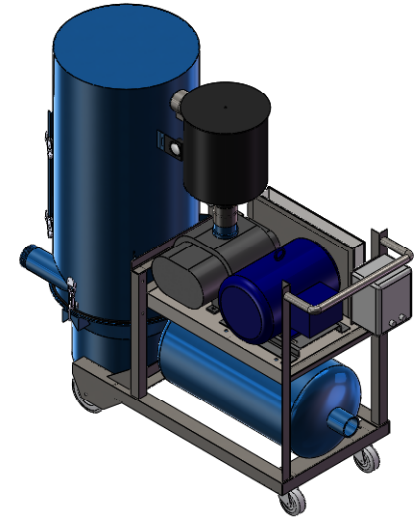
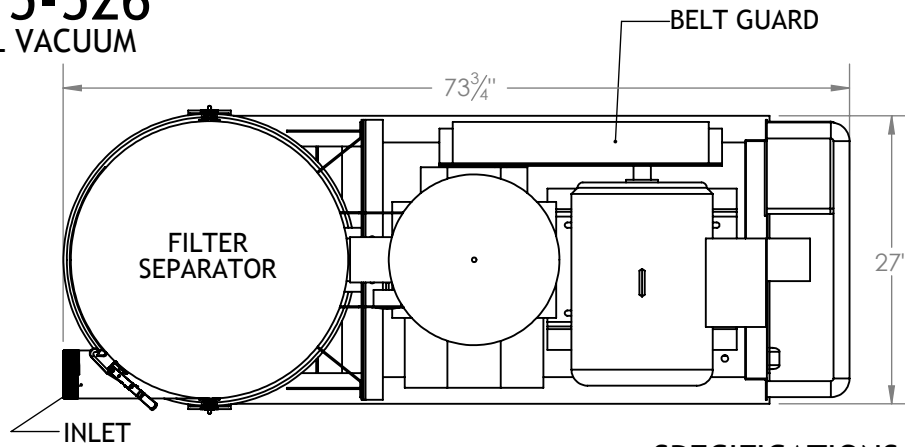

SPECIFICATIONS:

15HP TEFC MOTOR (VOLTAGE TO SUIT)
360 ICFM @ 12Hg
PRIMARY FILTER AREA: 61.6 SQFT
99.997% @ 0.4 MICRON EFFICIENT
DIRT CAPACITY: 27.0 GAL
NOISE: 90 dba
WEIGHT: 1100LBS

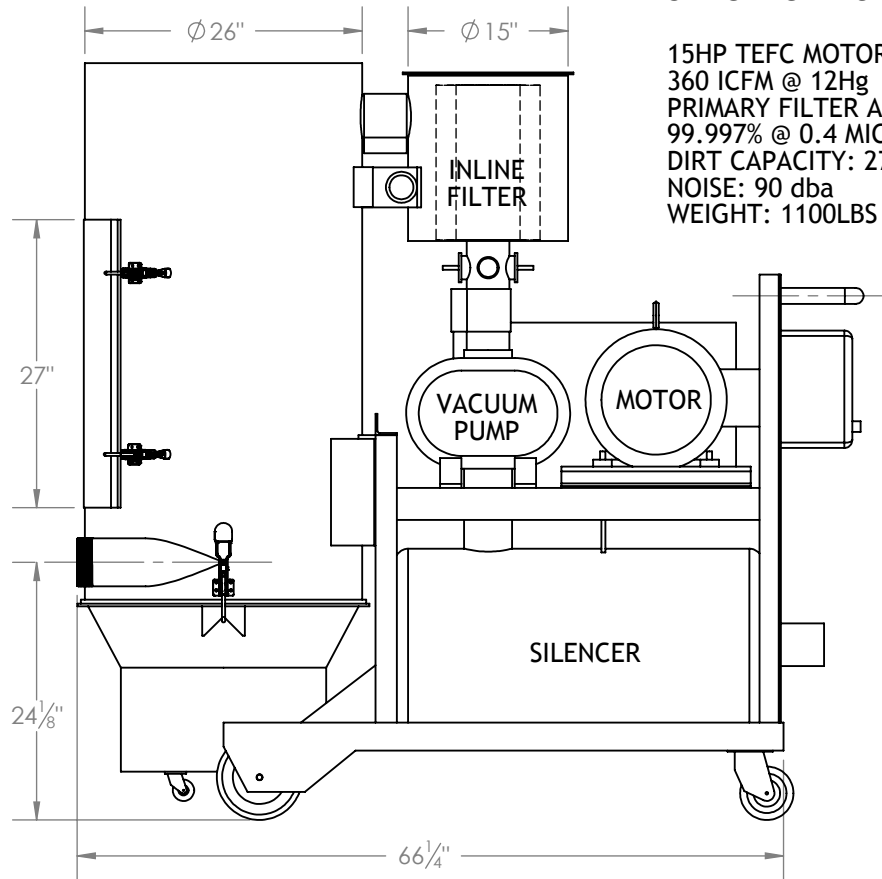

NEMA 4
STARTER
PANEL

HEAVY DUTY
WELDED STEEL
FRAME

TUNED
SILENCER

5" SWIVEL CASTERS

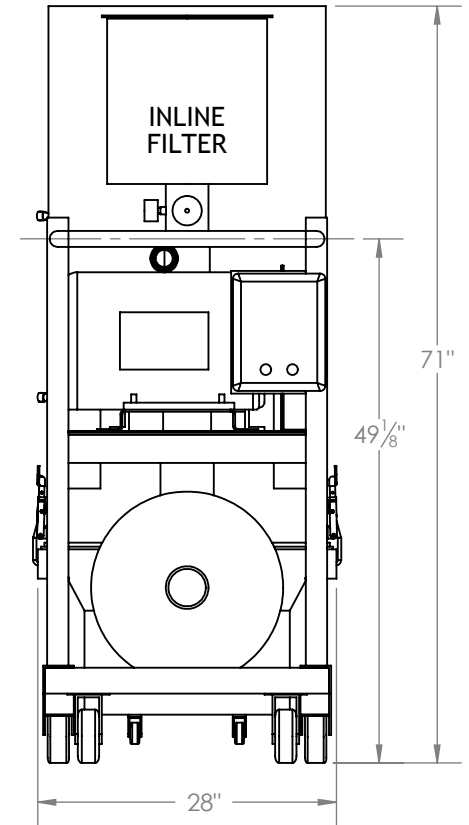

No.	DATE	COMMENTS
0	SEPT 09	ISSUED FOR REVIEW

DWG NO.	090929-01
BY: KS	DATE: SEPT 09

TITLE:	DVP15-526	CONTINUOUS DUTY
	15HP VACUUM	
SCALE:1:18	DO NOT SCALE DRAWING	SHEET 1 OF 1