

# MODEL DVR1553

## 15.0 HP VACUUM SYSTEM

LARGE, EASY ACCESS  
FILTER SERVICE DOOR

SUPER EFFICIENT  
FILTRATION

FILTER CONDITION  
INDICATOR GAUGE

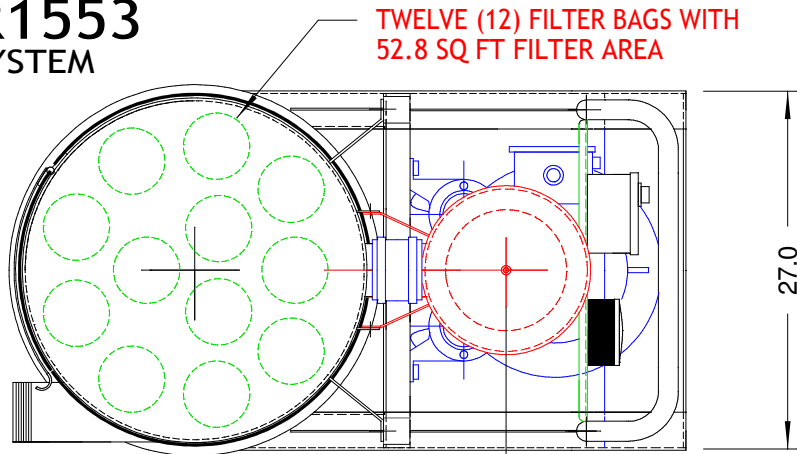

TWELVE (12) FILTER BAGS WITH  
52.8 SQ FT FILTER AREA

EFFECTIVE  
FILTER BAG  
SHAKER

FILTERS NEVER  
NEED CLEANING  
AS THE CANISTER  
FILLS.

OPTIONAL HEPA  
FILTER WITH  
CONDITION  
INDICATOR

OVERHEAD  
CRANE LIFT  
HOOKS

4" NPT  
INLET WITH  
INTERNAL  
WEAR STRIP

29.8 US GAL  
STORAGE DRUM

HEAVY DUTY  
8" FRONT  
WHEELS

26" DIAMETER  
BAGHOUSE FILTER

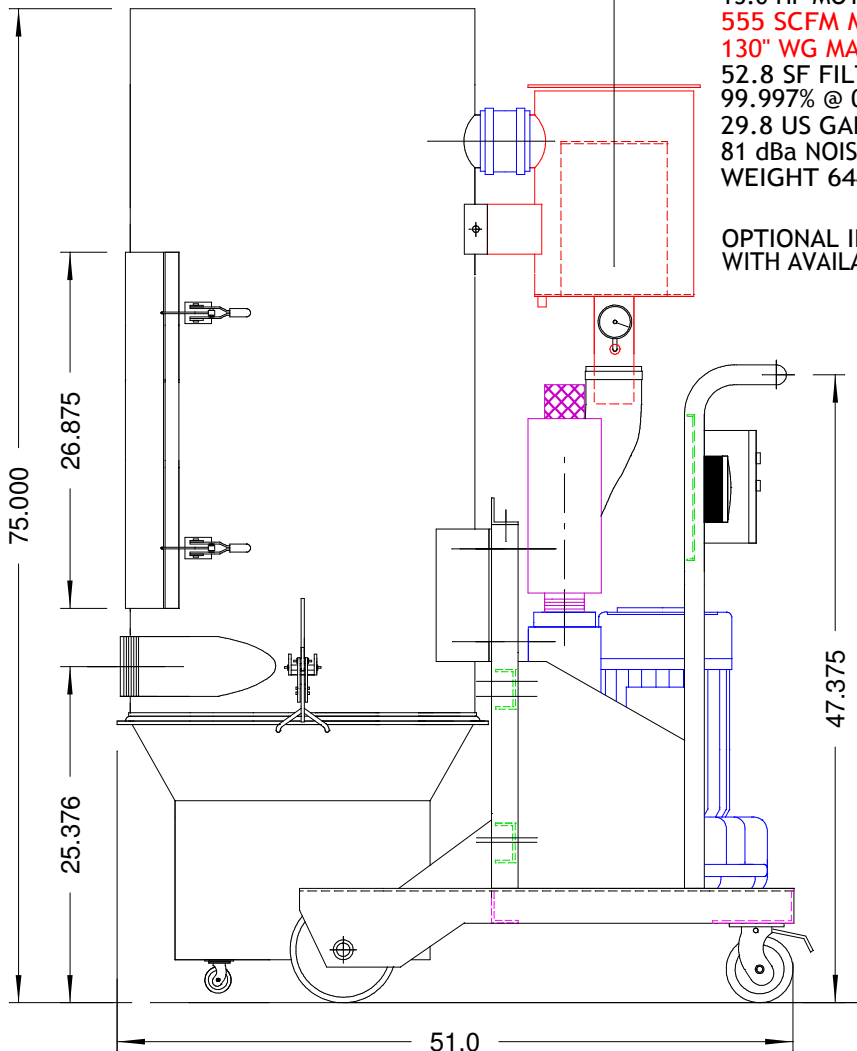

### SPECIFICATIONS:

15.0 HP MOTOR (VOLTAGE TO SUIT)  
555 SCFM MAX  
130" WG MAX VACUUM  
52.8 SF FILTER BAGS  
99.997% @ 0.4 MICRON EFFICIENT  
29.8 US GALLON STORAGE DRUM  
81 dBa NOISE LEVEL  
WEIGHT 644 LBS

OPTIONAL INLINE FILTER  
WITH AVAILABLE HEPA UPGRADE

VACUUM GAUGE  
& RELIEF VALVE  
STANDARD

NEMA 12  
STARTER PANEL  
& DP GAUGE

HEAVY DUTY ALL  
STEEL FRAME

15.0 HP  
QUIET, DEPENDABLE  
VACUUM PRODUCER

EFFECTIVE, BUILT-IN  
SILENCER

LOCKABLE  
5" SWIVEL CASTERS

			DATE:	OCT 2005	DUROVAC INDUSTRIAL VACUUMS BRAMPTON, ONT 888-330-3365
			DRAWN BY:	KRW	
			SCALE:	N.T.S.	
00	03 JUN 04	ISSUED FOR REVIEW	DRAWING No.	Rev.	<b>DuroVac</b> <b>DVR1553</b>
No.	DATE	REVISIONS	401018 DO1	00	